

Specifications

Model	Line Voltage (VAC)	Armature Voltage Range (VDC)	Continuous Armature Current (Amps)	Horsepower Range
PWM400-2	115	0 - 130	2.0	1/20 - 1/6
	230	0 - 240		1/10 - 1/3
PWM400-5	115	0 - 130	5.0	1/6 - 1/2
	230	0 - 240		1/3 - 1
PWM400-10	115	0 - 130	10.0*	1/2 - 1
	230	0 - 240		1 - 2

* Heat sink kit HSK-0001 must be used when the continuous output current is over 5 amps. 10 amps up to 25°C ambient. Derate to 7 amps when over 25°C ambient.

AC Line Voltage.....	115/230 VAC ± 10%, 50/60 Hz, single phase
Form Factor.....	1.05
Acceleration Time Range.....	0.5 - 6 seconds
Deceleration Time Range.....	coast to stop - 6 seconds
Analog Input Voltage Range (Signal must be isolated; S1 to S2).....	0 - 5 VDC
Input Impedance (S1 to S2).....	70K ohms
Load Regulation.....	1% base speed or better
Speed Range.....	100:1
Vibration (0 - 50 Hz).....	0.5G maximum
(>50 Hz).....	0.1G maximum
Ambient Temperature Range.....	10°C - 40°C
Weight.....	0.8 lbs
Safety Certifications.....	UL/cUL Recognized Equipment, file # E132235 CSA Certified Component, file # LR41380

Safety Warnings

- **DO NOT INSTALL, REMOVE, OR REWIRE THIS EQUIPMENT WITH POWER APPLIED.** Have a qualified electrical technician install, adjust and service this equipment. Follow the National Electrical Code and all other applicable electrical and safety codes, including the provisions of the Occupational Safety and Health Act (OSHA), when installing equipment.
- **Circuit potentials are at 115 or 230 VAC above earth ground.** Avoid direct contact with the printed circuit board or with circuit elements to prevent the risk of serious injury or fatality. Use a non-metallic screwdriver for adjusting the calibration trim pots. Use approved personal protection equipment and insulated tools if working on this drive with power applied.
- Reduce the chance of an electrical fire, shock, or explosion by using proper grounding techniques, over-current protection, thermal protection, and enclosure. Follow sound maintenance procedures.
- **ACE strongly recommends the installation of a master power switch in the line voltage input.** The switch contacts should be rated for 250 VAC and 200% of motor nameplate current.
- **Do not disconnect any of the motor leads from the drive** unless power is removed or the drive is disabled. Opening any one lead while the drive is running may destroy the drive.
- Under no circumstances should power and logic level wires be bundled together.
- Be sure potentiometer tabs do not make contact with the potentiometer's body. Grounding the input will cause damage to the drive.

Dimensions

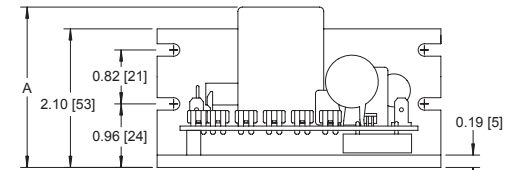
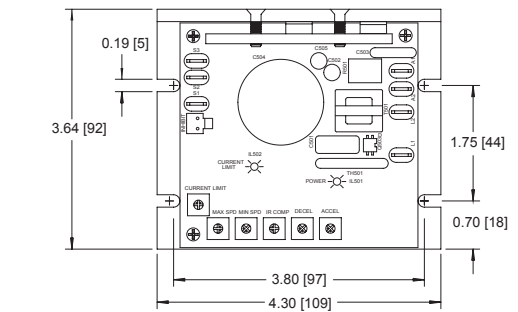

MODEL	DIMENSION "A" HEIGHT
PWM400-2	2.50 [62]
PWM400-5	3.20 [81]
PWM400-10	3.90 [99]

ALL DIMENSIONS IN INCHES [MILLIMETERS]

Installation

Mounting

- Drive components are sensitive to electrostatic discharge. Avoid direct contact with the circuit board. Hold the drive by the chassis or heat sink only.
- Protect the drive from dirt, moisture, and accidental contact.
- Provide sufficient room for access to the terminal block and calibration trim pots.
- Mount the drive away from heat sources. Operate the drive within the specified ambient operating temperature range.
- Prevent loose connections by avoiding excessive vibration of the drive.
- Mount the drive with its board in either a horizontal or vertical plane. Eight 0.19" (5 mm) wide slots in the chassis accept #8 pan head screws. Fasten either the large base or the narrow flange of the chassis to the subplate.
- The chassis should be earth grounded. Use a star washer beneath the head of at least one of the mounting screws to penetrate the anodized chassis surface and to reach bare metal.

Heat Sinking

The PWM400-10 requires an additional heat sink when the continuous armature current is above 5 amps. Use ACE heat sink kit part number HSK-0001. Use a thermally conductive heat sink compound (such as Dow Corning 340® Heat Sink Compound) between the chassis and the heat sink surface for optimal heat transfer.

Wiring

Use 18 - 24 AWG wire for logic wiring. Use 14 - 16 AWG wire for AC line and motor wiring.

Shielding Guidelines

As a general rule, ACE recommends shielding of all conductors. If it is not practical to shield power conductors, ACE recommends shielding all logic-level leads. If shielding of logic-level leads is not practical, the user should twist all logic leads with themselves to minimize induced noise. It may be necessary to earth ground the shielded cable. If noise is produced by devices other than the drive, ground the shield at the drive end. If noise is generated by the drive, ground the shield at the end away from the drive. Do not ground both ends of the shield.

Fusing

ACE drives require an external line fuse for protection. Use fast acting fuses rated for 250 VAC or higher and 150% of the maximum armature current. Fuse the HOT leg of the AC line when using 115 VAC and both lines when using 230 VAC.

Connections

POWER

Line Input
Connect the AC line power leads to terminals L1 and L2. ACE recommends the use of a double-pole, single-throw master power switch. The switch should be rated at a minimum of 250 VAC and 200% of motor current.

Motor

Connect the DC armature leads to terminals A1 and A2. If the motor does not spin in the desired direction, power down the drive and reverse these connections.

LOGIC

Speed Potentiometer

Use a 10K ohm, 1/4 W potentiometer for speed control. Connect the counter-clockwise end of the potentiometer to S1, the wiper to S2, and the clockwise end to S3. If the potentiometer works inversely of desired functionality, (i.e. to increase motor speed, you must turn the potentiometer counterclockwise), power off the drive and swap the S1 and S3 connections.

Inhibit

Short the INHIBIT terminals to coast the motor to zero speed. Open the INHIBIT terminals to accelerate the motor to set speed. Twist inhibit wires and separate them from power-carrying wires or sources of electrical noise. Use shielded cable if the inhibit wires are longer than 18 inches (46 cm). If shielded cable is used, ground only one end of the shield to earth ground. Do not ground both ends of the shield. **Do not use the inhibit for emergency stopping.**

ACE offers two accessory plug harnesses for connecting to the inhibit terminals; part number KTW-0001 [18 in (46 cm) leads] and part number KTW-0002 [36 in (91 cm) leads].

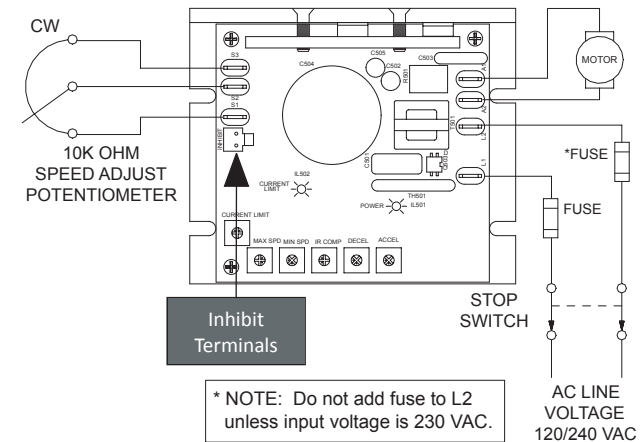

* NOTE: Do not add fuse to L2 unless input voltage is 230 VAC.

Startup

STARTUP

- Verify that no foreign conductive material is present on the printed circuit board.

1. Turn the speed adjust potentiometer full counterclockwise (CCW).
2. Apply AC line voltage.
3. Slowly advance the speed adjust potentiometer clockwise (CW). The motor slowly accelerates as the potentiometer is turned CW. Continue until the desired speed is reached.
4. Remove AC line voltage from the drive to coast the motor to a stop.

Operation

DECELERATING & STOPPING

Decelerate to Minimum Speed

The switch shown below may be used to decelerate a motor to a minimum speed. Closing the switch between S1 and S2 decelerates the motor from set speed to a minimum speed determined by the MIN SPD trim pot setting. If the MIN SPD trim pot is set full CCW, the motor decelerates to zero speed when the switch between S1 and S2 is closed. The DECEL trim pot setting determines the rate at which the drive decelerates. By opening the switch, the motor accelerates to set speed at a rate determined by the ACCEL trim pot setting.

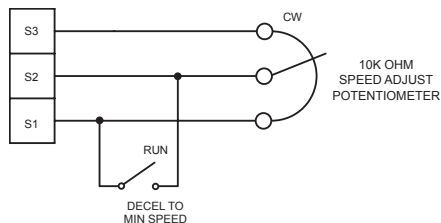

Decelerate to Zero Speed (Coast)

See INHIBIT in the CONNECTIONS section on page 1 for a description of wiring and connection locations.

Decelerate to Zero Speed (Dynamic Brake)

Dynamic braking may be used to rapidly stop a motor. For the RUN/BRAKE switch, use a two pole, two position switch rated for at least the armature voltage rating and 150% of the armature current rating. For the dynamic brake resistor, use a 40 watt minimum, high power, wirewound resistor. Sizing the dynamic brake resistor depends on load inertia, motor voltage, and braking time. Use a lower-value, higher-wattage dynamic brake resistor to stop a motor more rapidly. Recommended values are 15 ohms for a 130 VDC motor and 30 ohms for 240 VDC motor.

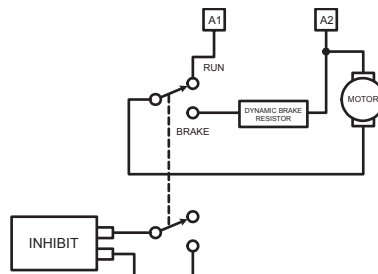

REVERSING

Reversing with a Dynamic Brake

A dynamic brake may be used when reversing the motor direction. Use a three pole, three position switch rated for at least the armature voltage rating and 150% of the armature current rating. For the dynamic brake resistor, use a 40 watt minimum, high power, wirewound resistor. Sizing the dynamic brake resistor depends on load inertia, motor voltage, and braking time. Use a lower-value, higher-wattage dynamic brake resistor to stop a motor more rapidly. Recommended values are 15 ohms for a 130 VDC motor and 30 ohms for 240 VDC motor. **The motor must come to a complete stop before changing directions.**

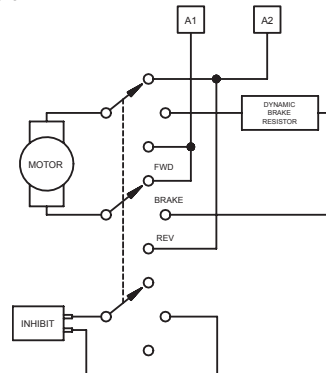

Calibration

Minimum Speed (MIN SPD): The MIN SPD setting determines the minimum motor speed when the speed adjust potentiometer is set for minimum speed. It is factory set for zero speed. To calibrate the MIN SPD:

1. Set the MIN SPD trim pot full CCW.
2. Set the speed adjust potentiometer for minimum speed.
3. Adjust the MIN SPD trim pot until the desired minimum speed is reached or is just at the threshold of rotation.

Maximum Speed (MAX SPD): The MAX SPD setting determines the maximum motor speed when the speed adjust potentiometer is set for maximum speed. To calibrate the MAX SPD:

1. Set the MAX SPD trim pot full CCW.
2. Set the speed adjust potentiometer for maximum speed.
3. Adjust the MAX SPD trim pot until the desired maximum speed is reached.

Check the MIN SPD and MAX SPD adjustments after recalibrating to verify that the motor runs at the desired minimum and maximum speed.

Torque (CURRENT LIMIT): The CURRENT LIMIT setting determines the maximum torque for accelerating and driving the motor. To calibrate the CURRENT LIMIT:

1. With the power disconnected from the drive, connect a DC ammeter in series with the armature.
2. Set the CURRENT LIMIT trim pot to minimum (full CCW).
3. Set the speed adjust potentiometer to maximum speed (full CW).
4. Carefully lock the motor armature. Be sure that the motor is firmly mounted.
5. Apply line power. The motor should be stopped.
6. Slowly adjust the CURRENT LIMIT trim pot CW until the armature current is 150% of motor rated armature current. **Continuous operation beyond this rating may damage the motor.**
7. Turn the speed adjust potentiometer CCW.
8. Remove line power.
9. Remove the stall from the motor.
10. Remove the ammeter in series with the motor armature if it is no longer needed.

IR Compensation (IR COMP): The IR COMP setting determines the degree to which motor speed is held constant as the motor load changes. To calibrate the IR COMP:

1. Set the IR COMP trim pot full CCW.
2. Increase the speed adjust potentiometer until the motor runs at midspeed without load. A handheld tachometer may be used to measure motor speed.
3. Load the motor armature to its full load armature current rating. The motor should slow down.
4. While keeping the load on the motor, rotate the IR COMP trim pot until the motor runs at the speed measured in step 2. If the motor oscillates (overcompensation), the IR COMP trim pot may be set too high (CW). Turn the IR COMP trim pot CCW to stabilize the motor.
5. Unload the motor.

Acceleration (ACCEL): The ACCEL setting determines the time the motor takes to ramp to a higher speed. ACCEL is factory set for the shortest acceleration time (full CCW). To calibrate the ACCEL:

1. Set the speed adjust potentiometer for minimum speed.
2. Set the speed adjust potentiometer for maximum speed. Measure the time it takes the motor to go from minimum speed to maximum speed.
3. If the time measured in step 2 is not the desired acceleration time, turn the ACCEL trim pot CW for a longer acceleration time, or CCW for a shorter acceleration time. Repeat steps 1 through 3 until the acceleration time is correct.

Deceleration (DECEL): The DECEL setting determines the time the motor takes to ramp to a lower speed. DECEL is factory set for the shortest deceleration time (full CCW). To calibrate the DECEL:

1. Set the speed adjust potentiometer for maximum speed.
2. Set the speed adjust potentiometer for minimum speed. Measure the time it takes the motor to go from maximum speed to minimum speed.
3. If the time measured in step 2 is not the desired deceleration time, turn the DECEL trim pot CW for a longer deceleration time, or CCW for a shorter deceleration time. Repeat steps 1 through 3 until the deceleration time is correct.

LEDs

Current Limit (CURRENT LIMIT): Red LED lights whenever the drive reaches current limit.

Power (POWER): Green LED lights whenever AC line voltage is applied to the drive.

